

Cascade Sierra  
Checkerboard Stripes Set



Designed by Diane Zangle

# Checkerboard Stripes Set

by Diane Zangl

*This matching pullover and cap will dress any child in contemporary style. The pullover features a classic silhouette with crew neckline, indented sleeves, and a buttoned shoulder for ease in dressing. The body is patterned in casual stripes and checks; the sleeves are plain. 1/1 ribbing is used on all edges, which are tipped with a contrasting color.*

*The hat is traditionally styled and include earflaps and ties to keep small heads warm. The checkerboard stripe motif is repeated in a single band. An I-cord loop finishes the top.*

## SKILL LEVEL

### SIZE

Child's 1 (2, 3, 4) year. Instructions are given for smallest size, with larger sizes in parentheses. When only 1 number is given, it applies to all sizes. Model shown in size 2 year.

## FINISHED MEASUREMENTS

**Chest:** 22 (23, 24, 26)"

**Head circumference:** 16 (17, 18, 19)"

**MATERIALS** Cascade Sierra; 80% Pima cotton, 20% wool (100g/191 yds per hanks): 2 (2, 3, 3) hanks #03 Natural (MC); 1 hank **each** #23 Lt Blue (A) and #50 Tan (B)

Size 4 (3.5mm) straight, 16" circular, and double-pointed needles

Size 5 (3.75mm) straight, 16" circular, and double-pointed needles **or size needed to obtain gauge**  
(3) buttons

Stitch holders and markers

## GAUGE

20 sts x 26 rows = 4" in St st with larger ndls

To save time and ensure proper fit, take time to check gauge.

## STITCH GLOSSARY

### 1/1 Rib

**Row 1 (WS):** P1, \*k1, p1; rep from \* across.

**Row 2:** K1, \*p1, k1; rep from \* across.

Rep Rows 1-2 for pat.

## PULLOVER

### BACK

With A and smaller needles, cast on 51 (55, 59, 63) sts. Change to MC.

Work even in 1/1 Rib for 1", inc 3 sts on last WS row – 54 (58, 62, 66) sts.

Change to larger needles and work even in chart pat until back measures 9 (9½, 10, 10)" from beg, ending with a WS row.

### Shape underarm

Bind off 7 (8, 8, 9) sts at beg of next 2 rows – 40 (42, 46, 48) sts. Work even in established pat until armhole measures 3½ (4, 4½, 5)" above bound-off underarm sts, ending with a WS row.

Mark center 12 (12, 14, 14) sts.

**Next row (RS):** Work to first marker, place rem sts on holder.

Dec 1 st at neck edge every RS row twice – 12 (13, 14, 15) sts.

Purl 1 row. Bind off remaining sts.

### **Shape back neck and left shoulder**

Sl sts from holder to needle. With RS facing, join yarn at next neck st. Bind off 12 (12, 14, 14) sts for back neck, work to end of row. Dec 1 st at neck edge every RS row twice – 12 (13, 14, 15) sts. Purl 1 row.

### **Button tab**

Work even in 1/1 rib for 3 rows. Bind off in rib.

### **FRONT**

Work as for back until armhole measures 2 (2½, 3, 3½)“ above bound-off underarm sts, ending with a WS row.

### **Shape shoulder**

Mark center 10 (10, 12, 12) sts.

**Next row (RS):** Work to marker, place remaining sts on holder.

Dec 1 st at neck edge every RS row 3 times – 12 (13, 14, 15) sts.

Work even in established pat until armhole measures 3 rows less than for back above bound-off underarm sts.

### **Make buttonholes**

Mark shoulder for 2 buttonholes evenly spaced. Third buttonhole will be in neckband.

**Next row (WS):** (Work to marker, yo, p2tog) twice, work to end of row.

Work 2 more rows in established pat.

Bind off all sts.

### **Shape front neck and right shoulder**

Sl sts from holder to needle. With RS facing, join yarn at next neck st. Bind off 10 (10, 12, 12) sts for front neck, work to end of row. Dec 1 st at neck edge every RS row 3 times – 12 (13, 14, 15) sts.

Work even until armhole measures same as for back above bound-off underarm sts.

Bind off all sts.

### **SLEEVES**

With A and smaller needles, cast on 25 (25, 27, 27) sts. Change to MC and work even in 1/1 Rib for 1½”, inc 3 (4, 3, 4) sts on last WS row – 28 (29, 30, 31) sts.

Change to larger needles.

Working in St st, inc 1 st each end every 6 (6, 4, 4)th row 6 (8, 10, 12) times – 40 (45, 50, 55) sts.

Work even until sleeve measures 7½ (8½, 9½, 10½)” from beg, ending with a WS row. Mark each end st for underarm.

Work even for 1½” above marker, ending with a WS row.

Bind off all sts.

### **NECKBAND**

Sew right shoulder seam. With smaller circular needle, pick up and knit 3 sts for every 4 rows or sts around neckline, including button tab. Adjust final number of sts, if necessary, to equal an odd number.

**Row 1 (WS):** P1, \*k1, p1, rep from \* to end.

**Row 2 (buttonhole row):** K1, p1, k1, yo, k2tog, work in established rib to end of row.

Work in 1/1 rib with MC for 2 rows, then with A for 1 row.

Bind off in rib with A.

### **ASSEMBLY**

At left shoulder, lap front over back tab; pin in place.

Sew sleeve into armhole, stitching through both layers at shoulder and matching underarm markers to first bound-off underarm sts.

Sew right sleeve into armhole. Sew sleeve and side seams. Sew buttons to shoulder.

## HAT

With A and smaller circular needle, cast on 80 (84, 88, 92) sts. Change to MC.

**Ribbing rnd:** \*K1, p1; rep from \* around.

Rep Ribbing rnd until rib measures 1". Change to larger needle.

Work 18 rnds of chart, rep between red lines only. Work even in MC only until hat measures 6 (6½, 7, 7½)" from beg.

### Shape crown

**Dec rnd:** K2tog around.

Knit 1 rnd. Rep last 2 rnds until 5 (6, 6, 6) sts remain, changing to dpn when necessary. Change to A.

**Next rnd:** K2tog twic., k1 (k2tog, k2tog, k2tog) – 3 sts.

### I-Cord loop

Using 2 dpn only, \*k3, sl sts just worked back to LH needle. Rep from \* until cord measures 1½". K3tog, fasten off last st.

Cut yarn leaving an 8" end. Sew end of cord to hat, forming a small loop.

### Earflaps

Mark first cast-on st at lower edge of hat as center back. Place markers 15 (15, 17, 17) sts to either side of center back marker. Place another set of markers 26 (26, 28, 28) sts to either side of center back marker. You will have 11 sts between each set of markers to denote earflap area.

With smaller dpn and MC, pick up and knit 1 st in each cast-on st between 1 set of markers – 11 sts.

Slipping first st of every row, work even in garter st for 13 (13, 15, 15) rows.

**Dec row:** Sl 1, k2tog, knit to end of row.

Rep Dec row until 3 sts remain.

### Tie

Work even in I-cord until tie measures 6".

K3tog, fasten off last st.

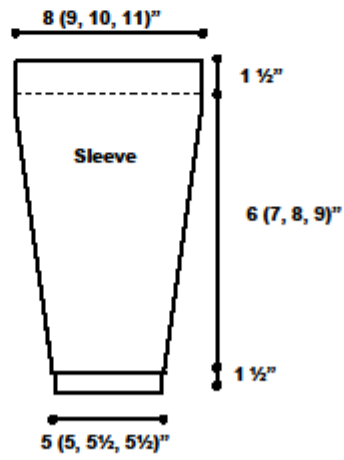
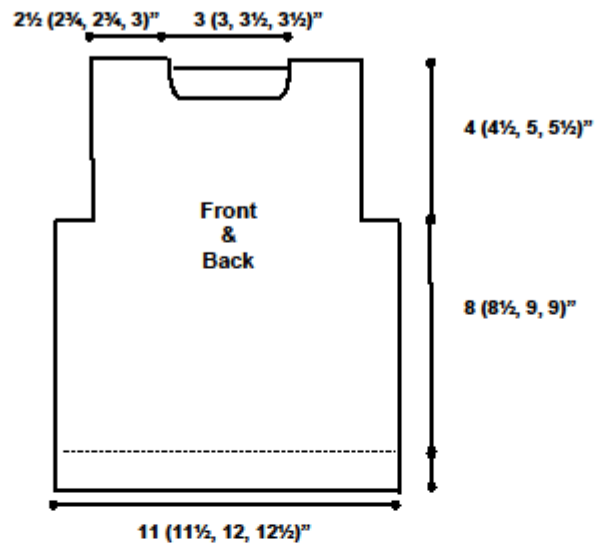

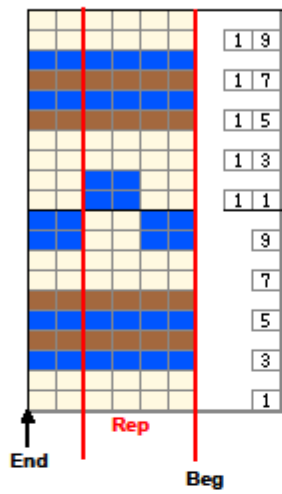

**Color Key**

- Natural (MC)
- Lt Blue (A)
- Tan (B)